

Parts List				
ITEM	QTY	PART NUMBER	DESCRIPTION	
1	2	1-6053	CHASSIS	
2	2	9-1997	SPACER SETTING TOOL	
3	2	9-2798	NYLON SHOULDER WASHER	
4	2	1-6029	ROSE, SMALL CONCEALED	
5	6	9-2201	No.4 X 1/2" CSK ZP POZI TWINS	

B-B (3:2)

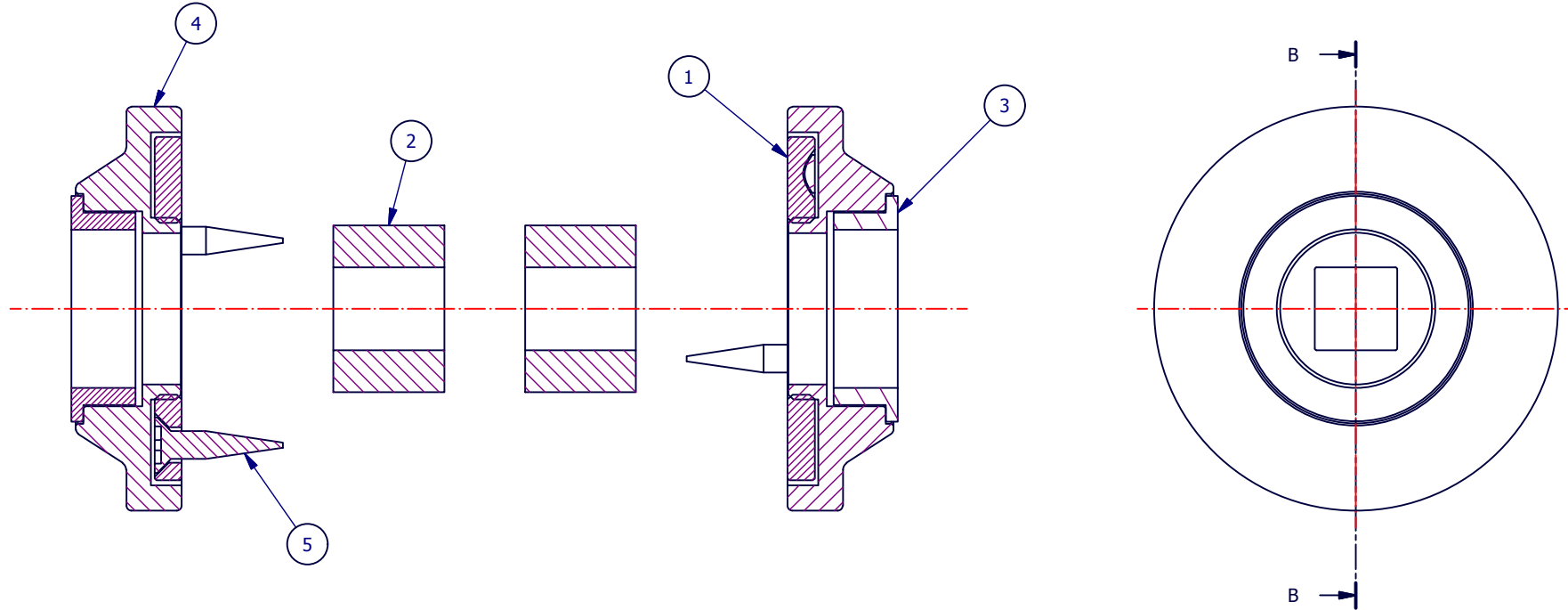

REVISION HISTORY

REV	DESCRIPTION	DATE
2	SCREWS WERE No.6	02.02.15

TOLERANCES UNLESS STATED
 DIMENSIONS ARE IN MILLIMETRES
 SURFACE TEXTURE VALUES ARE IN MICROMETRES
 MACHINE WHERE MARKED ✓

UP TO 6 ± 0.10
OVER 6 UP TO 30 ± 0.20
OVER 30 UP TO 120 ± 0.30
OVER 120 UP TO 315 ± 0.50
OVER 315 UP TO 1000 ± 0.50
OVER 1000 UP TO 2000 ± 0.50

MATERIAL	BRASS	SCALE	SEE DRW
BRASS MASS	0.095 kg	DRAWN BY	S.B
TREATMENT		DATE	09/01/14
FINISH	PLATED	CHECKED	A.D

TITLE:	40MM PROFILE CONCEALED ROSE
PROJECT:	

SHS
 Samuel Heath & Sons PLC

A4	THIRD ANGLE PROJ
ISS DATE	02.02.15
ISS NO	2
SHEET	1
DRG No	P8004

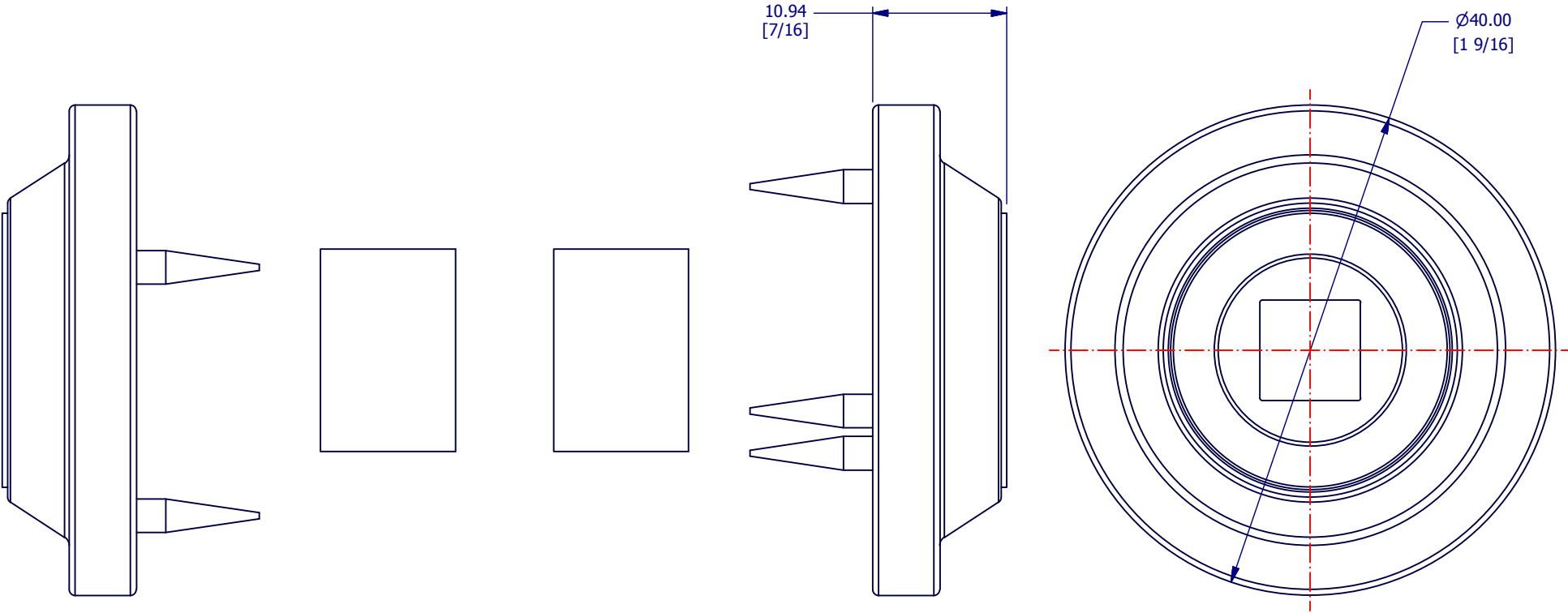

PROPERTY OF SAMUEL HEATH ©			DESIGNER	A.DANIELS	
A4	DRG No.	P8004	ISSUE NO.	2	ISSUE DATE 02.02.15

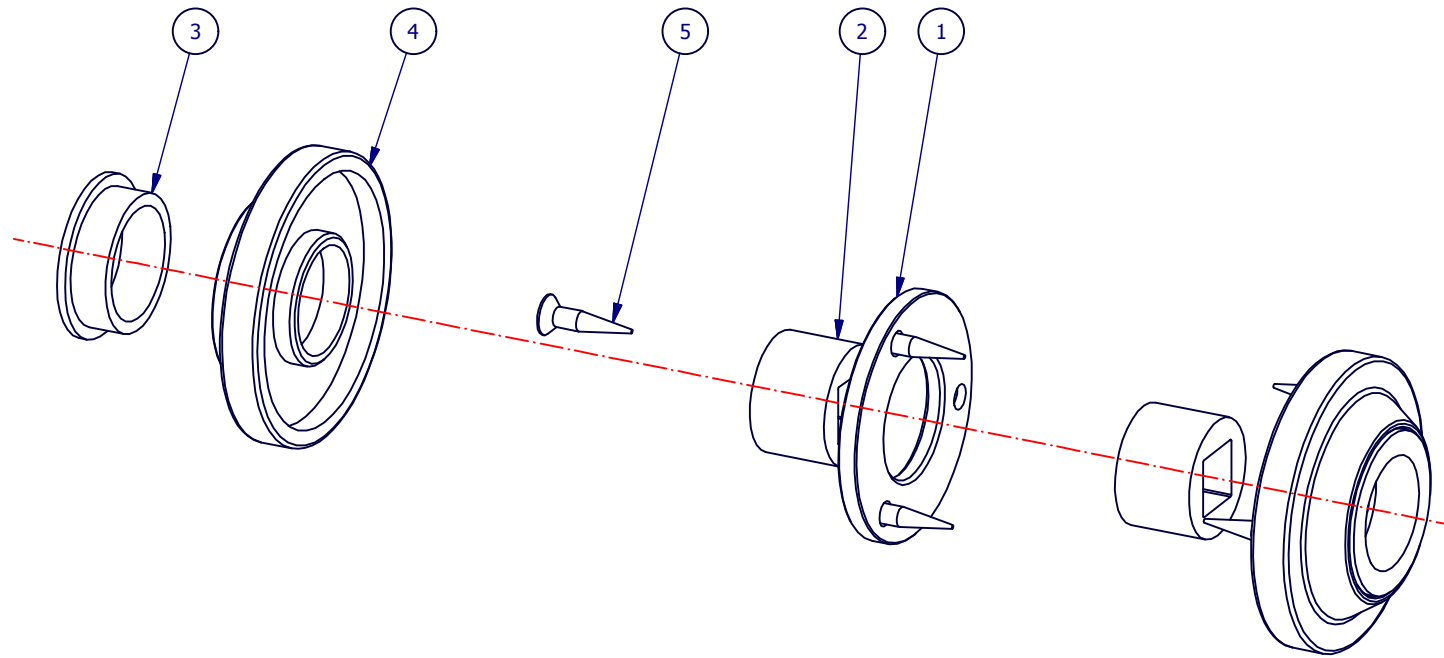

PROPERTY OF SAMUEL HEATH ©			DESIGNER	A.DANIELS		
A4	DRG No	P8004	ISSUE NO.	2	ISSUE DATE	02.02.15

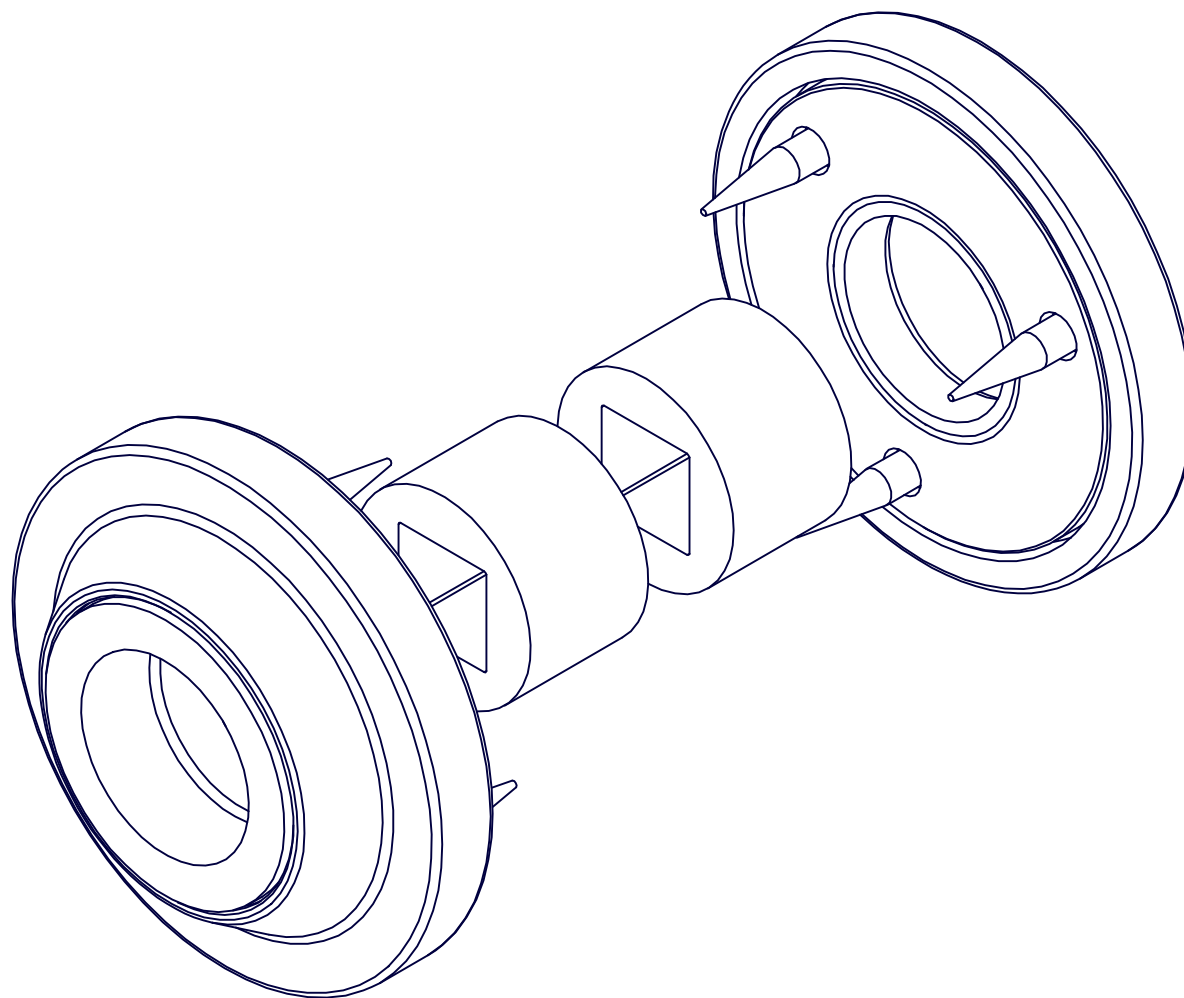

PROPERTY OF SAMUEL HEATH ©			DESIGNER	A.DANIELS	
A4	DRG No	P8004	ISSUE NO.	2	ISSUE DATE 02.02.15